



## Smart On-grid String Inverter Series

BSM-B2 Series 1.5~6KW

BSM-B Series 6~60KW

BSM-BHV Series 50-80KW



# Single-Phase On-grid String Inverter

TL-M1500-B2/ TL-M2000-B2



## Features

### High-efficiency

- High-efficiency inverter topology ensures annual power generation
- Advanced control algorithms and high adaptation ability to the grid, improving the stability of power generation system

### Safe and Reliable

- IP65 for outdoor application
- Integrated AC/DC full lightning protection
- Aluminum alloy die-casting integrated chassis, ensure 25 years full life circle running

### Intelligent Management

- Intelligent cloud platform monitoring, realizing one- key APP real-time monitoring
- Support RS485, GPRS, WIFI and other communication methods

### Green Saving

- Small size, easy to install and use
- Natural cooling, ensuring low environmental noise
- Super-wide operating temperature range, adapt to extremely cold, high temperature areas

## Function Diagram

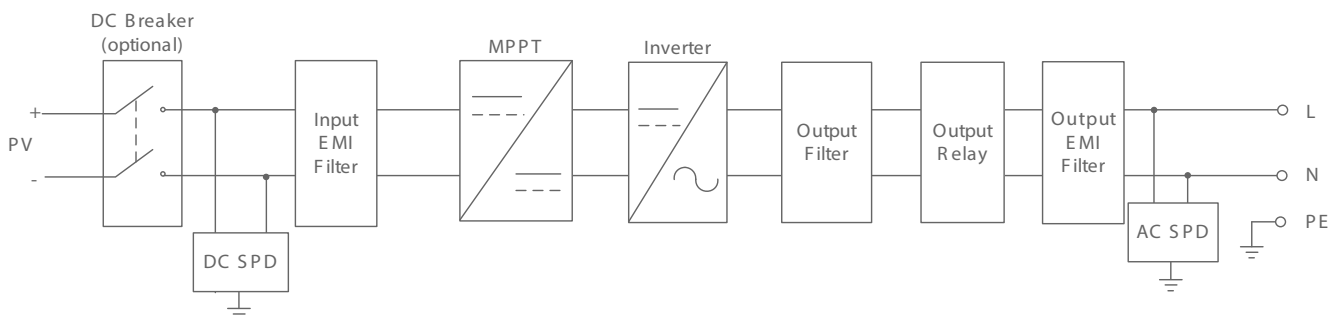

## Technical Specifications

Items	TL-M1500-B2	TL-M2000-B2
<b>DC Input</b>		
Max. PV input voltage	600Vdc	
Rated PV voltage	360Vdc	
Max. PV input current	11A	
No. of MPPTs	1	1
No. of PV strings per MPPT	1	
MPPT voltage range	100Vdc ~500Vdc	
Starting voltage	120Vdc	
<b>AC Output</b>		
Rated AC output power	1.5kW	2.0kW
Max. output power	1.65kVA	2.2kVA
Rated AC output voltage	220/230Vac	
Rated output current	6.5A	8.7A
Max. output current	7.2A	9.6A
Rated grid frequency	50/60Hz	
Grid frequency range	45~55Hz/55~65Hz	
Power factor	>0.99 full load	
Adjustable power factor	0.8(leading) ~ 0.8(lagging)	
THDi	<3% (rated power)	
<b>Efficiency</b>		
Max. efficiency	98.10%	
European efficiency	97.70%	
<b>Protection</b>		
Anti-islanding	Yes	
DC Reversed Connection	Yes	
AC Short Circuit protection	Yes	
Temperature protection	Yes	
Surge Protection	Yes	
PV Fault Detect	Yes	
DC Switch	Optional	
<b>General</b>		
Dimensions (W×H×D)	360×420×125mm	
Weight	11.8 kg	
IP grade	IP65	
Noise level	≤25 dB	
Self-consumption at night	<1W	
Cooling type	Natural cooling	
Altitude	4000m (>2000m derating )	
Operating temperature	-40°C~60°C (>45°C derating)	
Relative humidity	0~95% (Non-condensing)	
Display	LCD display + LED indicator	
Communication	RS485/WiFi (optional)/GPRS (optional)/DRM(Australia)	
DC terminal	MC4 Terminal	
AC terminal	Plug and play connector	
Installation method	Wall-mounted	
Standard	EN62109-1, EN62109-2 NB/T32004, AS3100, AS4777, EN 61000-6-2, EN 61000-6-3	

\*The specifications are subject to change without notice.

# Single-phase On-grid String Inverter

TL-M3000-B2/ TL-M3600-B2/ TL-M4000-B2/ TL-M4600-B2/ TL-M5000-B2/ TL-M6000-B2



## Features

### High-efficiency

- High-efficiency inverter topology ensures annual power generation
- Advanced control algorithms and high adaptation ability to the grid, improving the stability of power generation system

### Safe and Reliable

- IP65 for outdoor application
- Integrated AC/DC full lightning protection
- Aluminum alloy die-casting integrated chassis, ensure 25 years full life circle running

### Intelligent Management

- Intelligent cloud platform monitoring, realizing one- key APP real-time monitoring
- Support RS485, GPRS, WIFI and other communication methods

### Green Saving

- Small size, easy to install and use
- Natural cooling, ensuring low environmental noise
- Super-wide operating temperature range, adapt to extremely cold, high temperature areas

## Function Diagram

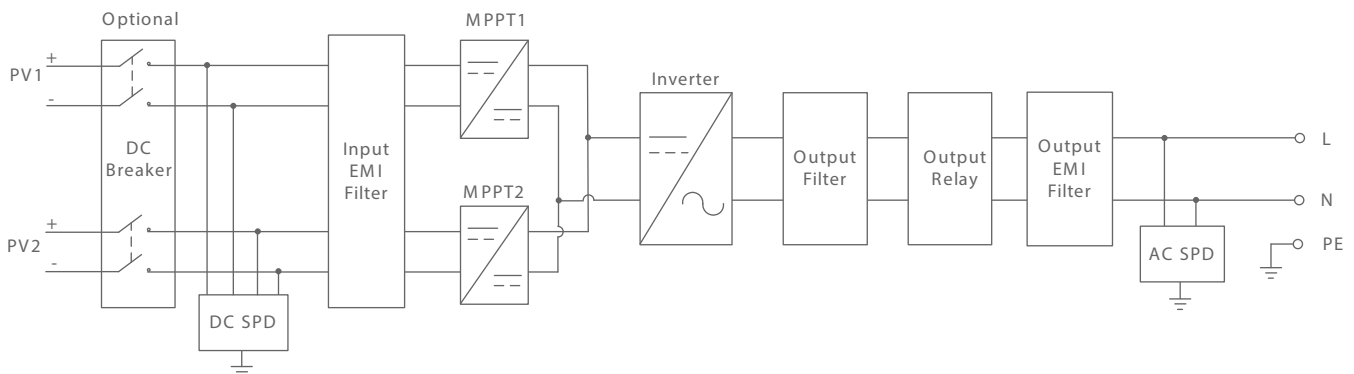

\*e.g.BSM4000-B2/5000-B2/6000-B2

## Technical Specifications

Items	TL-M3000-B2	TL-M3600-B2	TL-M4000-B2	TL-M4600-B2	TL-M5000-B2	TL-M6000-B2
<b>DC Input</b>						
Max. PV input voltage	600Vdc					
Rated PV voltage	360Vdc					
Max. PV input current	22A(2×11A)					
No. of MPPTs	2					
No.of PV strings per MPPT	1/1					
MPPT voltage range	100Vdc ~500Vdc					
Starting voltage	120Vdc					
<b>AC Output</b>						
Rated AC output power	3.0kW	3.6kW	4.0kW	4.6kW	5.0kW	6.0kW
Max. output power	3.3kVA	3.96kVA	4.4kVA	5.06kVA	5.5kVA	6.0kVA
Rated AC output voltage	220V/230Vac					
Rated output current	13.0A	15.7A	17.4A	20.0A	21.7A	26.0A
Max. output current	14.3A	17.2 A	19.1A	22.0 A	23.9 A	26.0 A
Rated grid frequency	50/60Hz					
Grid frequency range	45~55Hz/55~65Hz					
Power factor	>0.99 full load					
Adjustable power factor	0.8 (leading) ~ 0.8 (lagging)					
THDi	<3% (rated power)					
<b>Efficiency</b>						
Max. efficiency	98.10%					98.30%
European efficiency	97.70%					97.90%
<b>Protection</b>						
Anti-islanding	Yes					
DC Reversed Connection	Yes					
AC short circuit protection	Yes					
Temperature protection	Yes					
Surge protection	Yes					
PV fault detect	Yes					
DC switch	optional					
<b>General</b>						
Dimensions (W×H×D)	360×420×125 mm					
Weight	12.6kg					
IP grade	IP65					
Noise level	≤25 dB					
Night power consumption	<1W					
Cooling type	Natural cooling					
Altitude	4000m (>2000m derating )					
Operating temperature	-40°C~60°C (>45°C derating)					
Relative humidity	0~95%					
Display	LCD display + LED indicator					
Communication	RS485/WiFi (optional)/GPRS (optional)/DRM(Australia)					
DC terminal	MC4 Terminal					
AC terminal	Plug and play connector					
Installation method	Wall-mounted					
Standard	EN62109-1, EN62109-2 NB/T32004, AS3100, AS4777, EN 61000-6-2, EN 61000-6-3 , IEC 62116:2014 ,IEC 61727:2004 ,IEC 60068-2-1:2007 ,IEC 60068-2-2:2007 ,IEC 60068-2-14:2009 ,IEC 60068-2-30:2005					

\*The specifications are subject to change without notice.

# Three-phase On-grid String Inverter

TL-M5K-B/ TL-M6K-B / TL-M8K-B/ TL-M10K-B/ TL-M12K-B



## Features

### Efficient and Flexible

- 2 independent MPPT, more generation
- Advanced control algorithms and high adaptation ability to the grid, improving the stability of power generation system

### Safe and Reliable

- IP65 for outdoor application
- Integrated AC/DC full lightning protection
- All industrial grade electronic device, ensure 25 years full life circle running

### Intelligent Management

- I&V Intelligent diagnosis, accurate identification and positioning of abnormal PV panels
- Support RS485, Wifi, GPRS communication
- Remote online upgrade, convenient and efficient

### Grid Friendly

- Grid-connected current harmonics <3%, green adapts to grid
- Ultra wide grid voltage range, with LVRT function

## Function Diagram

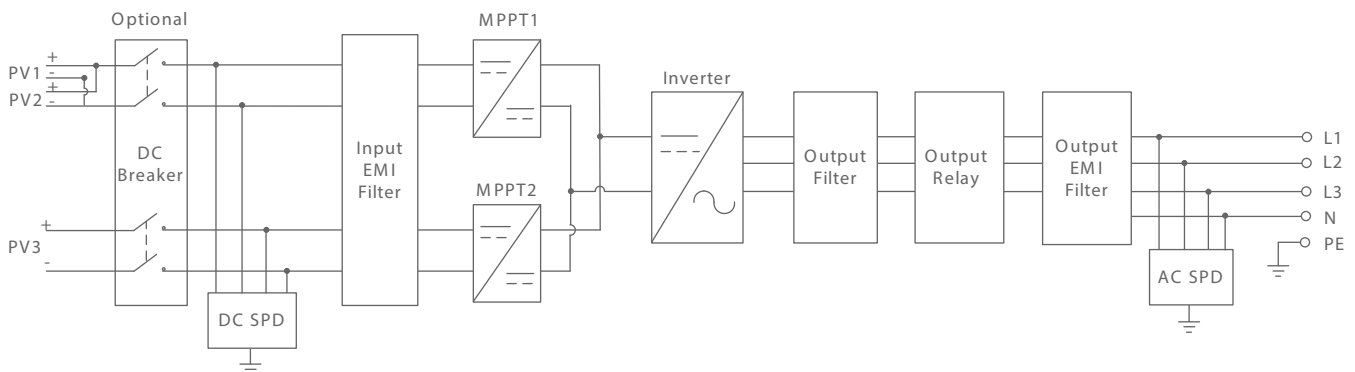

\*e.g.B5M 10K-B

## Technical Specifications

Items	TL-M5K-B	TL-M6K-B	TL-M8K-B	TL-M10K-B	TL-M12K-B
<b>DC Input</b>					
Max. PV Input Voltage	1000Vdc				
Rated PV voltage	600Vdc				
Max. PV Input Current	22A(2×11A)	22A(2×11A)	33A(3×11A)	33A(3×11A)	22A(2×11A)
No. of MPPTs	2	2	2	2	2
No. of PV strings per MPPT	1/1	1/1	2/1	2/1	1/1
MPPT voltage range	200Vdc~950Vdc				
Starting voltage	200Vdc				
<b>AC Output</b>					
Rated AC output power	5kW	6kW	8kW	10kW	12kW
Max. output power	5.5kVA	6.6kVA	8.8kVA	11kVA	13.2kVA
Rated AC output voltage	380/400/415Vac				
Rated output current	7.3A	8.7A	11.6A	14.5A	17.4A
Max. output current	8.0A	9.6A	12.8A	15.9A	19.1A
Rated grid frequency	50Hz/60Hz				
Grid frequency range	45~55Hz/55~65Hz				
Power factor	>0.99 (full load)				
Adjustable power factor	0.8 (leading)-0.8 (lagging)				
THDi	<3% (rated power)				
<b>Efficiency</b>					
Max. efficiency	98.50%				
European efficiency	98.00%				
<b>Protection</b>					
Anti-islanding	Yes				
DC reversed connection	Yes				
AC short circuit protection	Yes				
Temperature protection	Yes				
Surge protection	Yes				
PV fault detect	Yes				
DC switch	optional				
<b>General</b>					
Dimensions (W×H×D)	480×420×180mm				
Weight	23kg				
IP grade	<30dB				
Noise level	IP65				
Self-consumption at night	<1W				
Cooling type	Natural cooling				
Altitude	4000m (>3000m derating)				
Operating temperature	-25°C~+60°C(>45°C derating)				
Relative humidity	0~95% (Non-condensation)				
Display	LCD+LED				
Communication	RS485/WiFi/GPRS/DRM(Australia)				
DC terminal	MC4 Terminal				
AC terminal	OT Terminal				
Installation method	Wall-mounted				
Standard	EN62109-1, EN62109-2 NB/T32004, AS3100, AS4777, EN 61000-6-2, EN 61000-6-3, IEC 62116:2014, IEC 61727:2004, IEC 60068-2-1:2007, IEC 60068-2-2:2007, IEC 60068-2-14:2009, IEC 60068-2-30:2005				

\*The specifications are subject to change without notice.

# Three-phase On-grid String Inverter

TL-M12K-BL/ TL-M15K-B/ TL-M17K-B/ TL-M20K-B



## Features

### Efficient and Flexible

- 2 independent MPPT, more generation
- Advanced control algorithms and high adaptation ability to the grid, improving the stability of power generation system

### Safe and Reliable

- IP65 for outdoor application
- Integrated AC/DC full lightning protection
- All industrial grade electronic device, ensure 25 years full life circle running

### Intelligent Management

- I&V Intelligent diagnosis, accurate identification and positioning of abnormal PV panels
- Support RS485, Wifi, GPRS communication
- Remote online upgrade, convenient and efficient

### Grid Friendly

- Grid-connected current harmonics <3%, green adapts to grid
- Ultra wide grid voltage range, with LVRT function

## Function Diagram

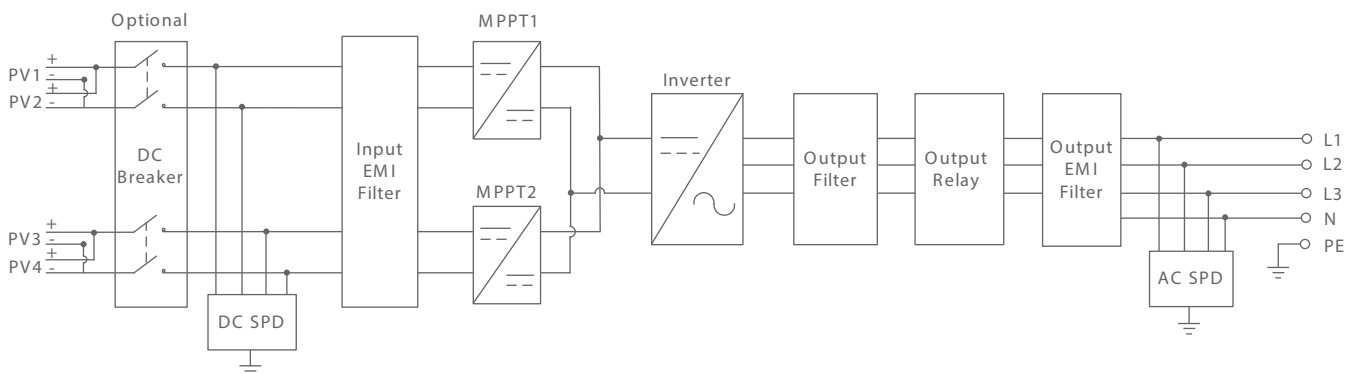

\*e.g.BSM17K-B/20K-B

## Technical Specifications

Items	TL-M12K-BL	TL-M15K-B	TL-M17K-B	TL-M20K-B
<b>DC Input</b>				
Max. PV Input Voltage	1000Vdc			
Rated PV voltage	600Vdc			
Max. PV Input Current	44A(4×11A)	44A(4×11A)	44A(4×11A)	44A(4×11A)
No. of MPPTs	2	2	2	2
No. of PV strings per MPPT	2/2	2/2	2/2	2/2
MPPT voltage range	200Vdc~950Vdc			
Starting voltage	200Vdc			
<b>AC Output</b>				
Rated AC output power	12kW	15kW	17kW	20kW
Max. output power	13.2kVA	16.5kVA	18.7kVA	22kVA
Rated AC output voltage	380/400/415Vac			
Rated output current	17.4A	21.7A	24.6A	29.0A
Max. output current	19.1A	23.9A	27.1A	31.9A
Rated grid frequency	50Hz/60Hz			
Grid frequency range	45~55Hz/55~65Hz			
Power factor	>0.99 (full load)			
Adjustable power factor	0.8 (leading)-0.8 (lagging)			
THDi	<3% (rated power)			
<b>Efficiency</b>				
Max. efficiency	98.50%		98.60%	
European efficiency	98.00%		98.30%	
<b>Protection</b>				
Anti-islanding	Yes			
DC reversed connection	Yes			
AC short circuit protection	Yes			
Temperature protection	Yes			
Surge protection	Yes			
PV fault detect	Yes			
DC switch	Optional			
<b>General</b>				
Dimensions (W×H×D)	480×420×180mm			
Weight	25kg			
IP grade	IP65			
Noise level	<50dB			
Self-consumption at night	<1W			
Cooling type	Intelligent forced air cooling			
Altitude	4000m (>3000m derating)			
Operating temperature	-25°C~+60°C(>45°C derating)			
Relative humidity	0~95% (Non-condensation)			
Display	LCD+LED			
Communication	RS485/WiFi/GPRS/DRM(Australia)			
DC terminal	MC4 Terminal			
AC terminal	OT Terminal			
Installation method	Wall-mounted			
Standard	EN62109-1, EN62109-2 NB/T32004, AS3100, AS4777, EN 61000-6-2, EN 61000-6-3, IEC 62116, IEC 61727, IEC 60068-2-1, IEC 60068-2-2, IEC 60068-2-14, IEC 60068-2-30			

\*The specifications are subject to change without notice.

# Three-phase On-grid String Inverter

TL-M30K-B/ TL-M33K-B/ TL-M36K-B/ TL-M40K-B/ TL-M50K-B/ TL-M60K-B



## Features

### High Efficient

- 3level topology, maximum efficiency 99.00%
- 3/4 MPPT design

### Safe and Reliable

- Outdoor IP65 design, no derating below 3000m altitude
- All industrial grade electronic device, ensure 25 years full life circle running

### Intelligent Management

- Intelligent fault wave recording, quick failure analysis & V Intelligent diagnosis, accurate identification and positioning of abnormal PV panels
- Intelligent online upgrade function, easy upgrade and maintain
- Support RS485, Wifi, GPRS communication

### Grid Friendly

- Grid-connected current harmonics <3%, green adapts to grid
- Ultra wide grid voltage range, with LVRT function

## Function Diagram

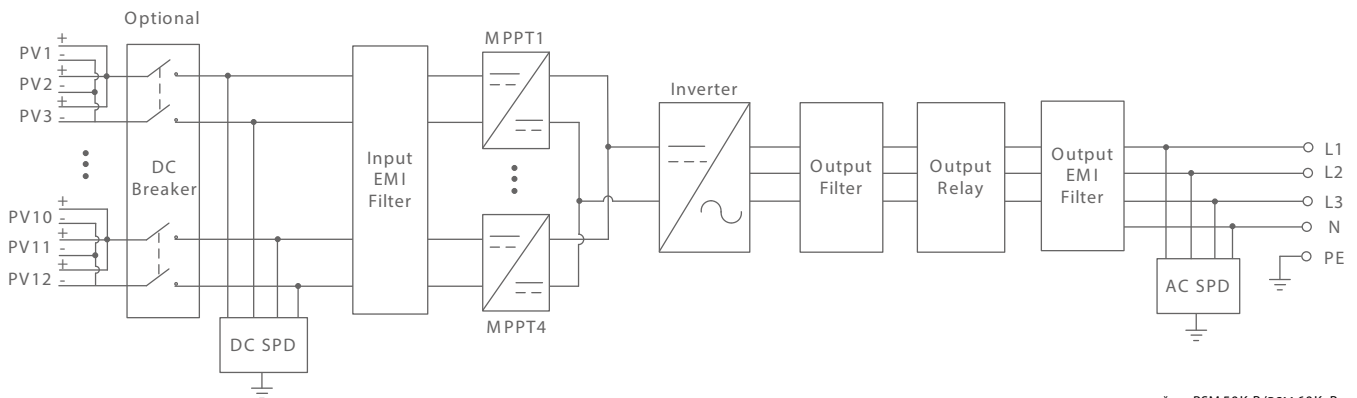

\*e.g.BSM 50K-B/BSM 60K-B

## Technical Specifications

Items	TL-M30K-B	TL-M33K-B	TL-M36K-B	TL-M40K-B	TL-M50K-B	TL-M60K-B
<b>DC Input</b>						
Max. PV Input Voltage	1100Vdc					
Rated PV voltage	600Vdc	600Vdc	600Vdc	600Vdc	600Vdc	600Vdc
Max. PV input current	60A(6x10A)	67A(2x33.5 A)	67A(2x33.5 A)	90A(9x10 A)	120A(12x10A)	120A(12x10A)
No. of MPPTs	2	2	2	3	4	4
No.of PV strings per MPPT	3/3	3/3	3/3	3/3/3	3/3/3/3	3/3/3/3
MPPT voltage range	300Vdc~1000Vdc					
Starting voltage	250Vdc					
<b>AC Output</b>						
Rated AC output power	30kW	33kW	36kW	40kW	50kW	60kW
Max. output power	30kVA	36.3kVA	40kVA	44kVA	55kVA	66kVA
Rated AC output voltage	380/400/415Vac					
Rated output current	45.6A	50.1A	54.7A	60.8A	75.9A	91.2A
Max. output current	47.6 A	52 A	57.7 A	63.5 A	79.4 A	95.3 A
Rated grid frequency	50Hz/60Hz					
Grid frequency range	45~55Hz/55~65Hz					
Power factor	>0.99 (full load)					
Adjustable power factor	0.8 (leading)-0.8 (lagging)					
THDi	<3% (rated power)					
<b>Efficiency</b>						
Max. efficiency	98.50%	98.50%	98.70%	98.80%	98.80%	98.80%
European efficiency	98.30%	98.30%	98.30%	98.30%	98.40%	98.45%
<b>Protection</b>						
Anti-islanding	Yes					
DC reversed connection	Yes					
AC short circuit protection	Yes					
Temperature protection	Yes					
Surge protection	Yes					
PV fault detect	Yes					
DC switch	Yes					
<b>General</b>						
Dimensions (W×H×D)	600×860×294mm					
Weight	68kg					
IP grade	IP65					
Noise level	<65dB					
Self-consumption at night	<1W					
Cooling type	Intelligent forced air cooling					
Altitude	4000m (>3000m derating)					
Operating temperature	-25°C~+60°C(>45°C derating)					
Relative humidity	0~95% (Non-condensation)					
Display	LCD+LED					
Communication	RS485/WiFi/GPRS(Optional)					
DC terminal	MC4 Terminal					
AC terminal	OT Terminal					
Installation method	Wall-mounted					
Standard	EN62109-1, EN62109-2, NB/T32004, AS4777.2,EN 61000-6-2, EN 61000-6-4, DIN VDE0126, UTE C15-712-1, VFR2014, ERDF-NOI-RES_13E, IEC61727, IEC62116					

\*The specifications are subject to change without notice.

# Three-phase On-grid String Inverter

TL-M50K-BHV/ TL-M60K-BHV/ TL-M70K-BHV/ TL-M80K-BHV



## Features

### High Efficient

- tri-level circuit topology, maximum conversion efficiency 99.00%
- Multi-MPPT design, strong complex installation environment adaptability
- 45° C 1.1 times the long-term overload, 50° C full load operation

### Safe and Reliable

- Outdoor IP65 design, no derating below 3000m altitude
- Intelligent fan, low temperature rise, long life
- PID protective function, avoid electrical shock

### Intelligent Management

- Intelligent fault wave recording, quick failure analysis
- I&V Intelligent diagnosis, accurate identification and positioning of abnormal PV panels
- Intelligent online upgrade function, easy upgrade and maintain
- Support RS485, PLC and other communication

### Grid Friendly

- Grid-connected current harmonics <3%, green adapts to grid
- Ultra wide grid voltage range, with LVRT function

## Function Diagram

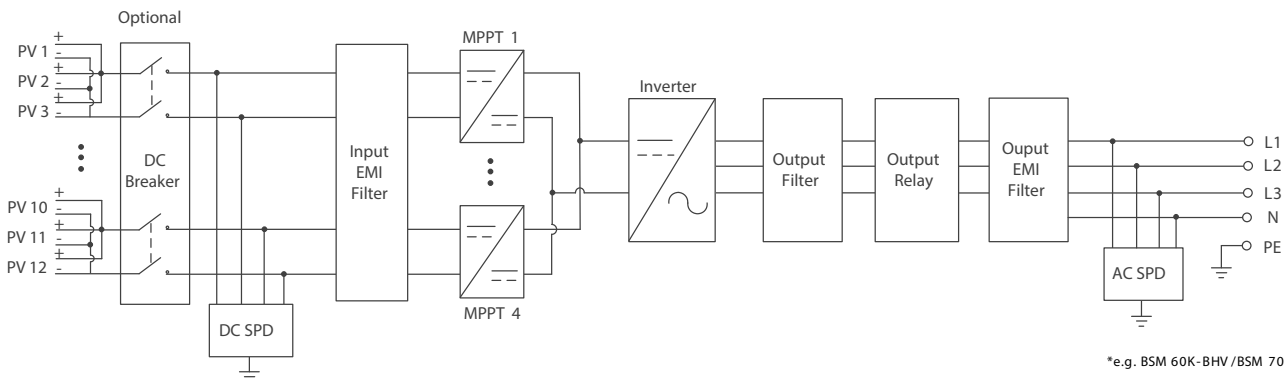

\*e.g. BSM 60K-BHV / BSM 70K-BHV

## Technical Specifications

Items	TL-M50K-BHV	TL-M60K-BHV	TL-M70K-BHV	TL-M80K-BHV
<b>DC Input</b>				
Max. PV input voltage	1000Vdc		1100Vdc	
Rated PV voltage	710Vdc	740Vdc	800Vdc	800Vdc
Max. PV input current	120A (12×10A)	120A (12×10A)	120A (12×10A)	176A (16×11A)
No. of MPPTs	4	4	4	4
No. of PV strings per MPPT	3/3/3/3	3/3/3/3	3/3/3/3	4/4/4/4
MPPT voltage range	300V~1000V			
Starting voltage	250Vdc			
<b>AC Output</b>				
Rated AC output power	50kW	60kW	70kW	80kW
Max. output power	55kVA	66kVA	77kVA	88kVA
Rated AC output voltage	480Vac		540Vac	540Vac
Rated output current	57.7A	72.2A	74.8A	85.5A
Max. output current	63.5A	79.4A	82.3A	94.1A
Rated grid frequency	50Hz/60Hz			
Grid frequency range	45~55Hz/55~65Hz			
Power factor	>0.99 (full load)			
Adjustable power factor	0.8 (leading)-0.8 (lagging)			
THDi	<3% (rated power)			
<b>Efficiency</b>				
Max. efficiency	98.8%		99%	
European efficiency	98.49%	98.49%	98.49%	98.5%
<b>Protection</b>				
Anti-islanding	Yes			
DC reversed connection	Yes			
AC short circuit protection	Yes			
Temperature protection	Yes			
Surge protection	Yes			
PV fault detect	Yes			
DC switch	Yes			
<b>General</b>				
Dimensions (W×H×D)	600×860×294mm			
Weight	65kg		76.5kg	
IP grade	IP65			
Noise level	<65dB			
Self-consumption at night	<1W			
Cooling type	Intelligent forced air cooling			
Altitude	5000m (>3000m derating)			
Operating temperature	-25°C~+60°C(>45°C derating)			
Relative humidity	0~95% (Non-condensation)			
Display	LCD+LED			
Communication	Ethernet/RS485/WIFI/GPRS(Optional)		RS485/WiFiGPRS/PLC(Optional)	
DC terminal	MC4 Terminal			
AC terminal	OT Terminal			
Installation method	Wall-mounted			
Standard	EN62109-1, EN62109-2, NB/T32004, AS4777.2, EN 61000-6-2, EN 61000-6-4, DIN VDE0126, UTE C15-712-1, VFR2014, ERDF-NOI-RES_13E, IEC61727, IEC62116, GB/T 19964-2012			

\*Specifications are subject to change without prior notice.

# Distributed Energy Monitoring and Management System



## Features

### Security of Assets

- 7x24 hours uninterrupted monitoring, ensure the safety

### Intelligent and Flexible

- Compatible with multiple communication interfaces and protocols to meet the needs of multiple scenarios
- Push alarms and faults in time to improve work efficiency

### Efficient Operation and Maintenance

- Quickly locate abnormal strings and faulty devices to improve the efficiency of operation and maintenance

### Assisting Decision-making

- Equipment type, personnel cost, financing risk assessment

## Function List

Key Functions	Monitoring System	Management System	Operation APP
KPI of Power Station		•	
Compare Report Management		•	
PR Analysis		•	
Configuration Management		•	
String Intelligent Analysis.		•	
Power Station Asset Management.		•	
Remote Expert Diagnosi		•	
Defect Management		•	
Checking Management		•	
Sub-station Asset Management		•	•
Inverter Monitoring	•		•
Combiner Box	•		•
Strings Monitoring	•		•
Weather Station Monitoring	•		
SVG Function	•		

## WiseSolar ——Mobile APP

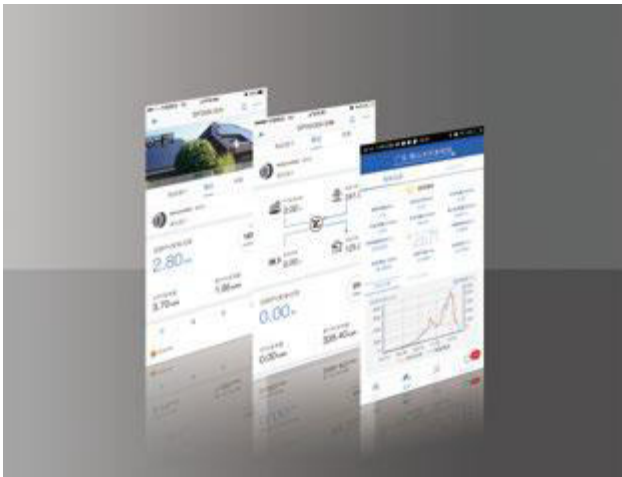

### Features

#### Smart and Convenient

- Flexible access
- Cloud data support
- Timely alarm fault information

#### Safe and Reliable

- 7x24 hours uninterrupted monitoring, ensure the safety
- Data redundancy backup to ensure data security

#### Simple Operation

- Process is simple, mobile phone can complete the onsite monitoring
- Data visualization, graphs are simple and easy to understand

### Function List

Basic Parameters	
Supported Language	Chinese/ English
Supported OS	Android/iOS
Key Functions	
Power Station Overview	Power station real-time operation state, current generation power, cumulative power
Devices Overview	Displays the status of the running devices
History Log	Daily, weekly, monthly, total power generation, etc.
Event Log	Display all warning, notice, check the power station notice, etc
Power Station Edit	Can add power station, add device, remove power station and so on.
User Management	Personal information, user registration, user login, user exit, etc.



T-Luce Italia srl  
Viale Giacomo  
Matteotti 15, Firenze 50121  
Italy

[info@t-luce.com](mailto:info@t-luce.com)  
+39 3281425503